

(PL) INSTRUKCJA OBSŁUGI DRZWI PRYSZNICOWYCH ETNA
(SK) NÁVOD NA MONTÁŽ A POUŽÍVANIE SPRCHOVE DVERE ETNA
(CZ) NÁVOD SPRCHOVÉ DVERE ETNA
(HU) SZERELÉSI ÚTMUTATÓ ZUHANYAJTÓK ETNA
(HR) KORISNIČKI PRIRUČNIK TUŠ VRATA ETNA
(SRB) UPUTSTVO ZA UPOTREBU VRATA ZA TUŠ KABINU ETNA

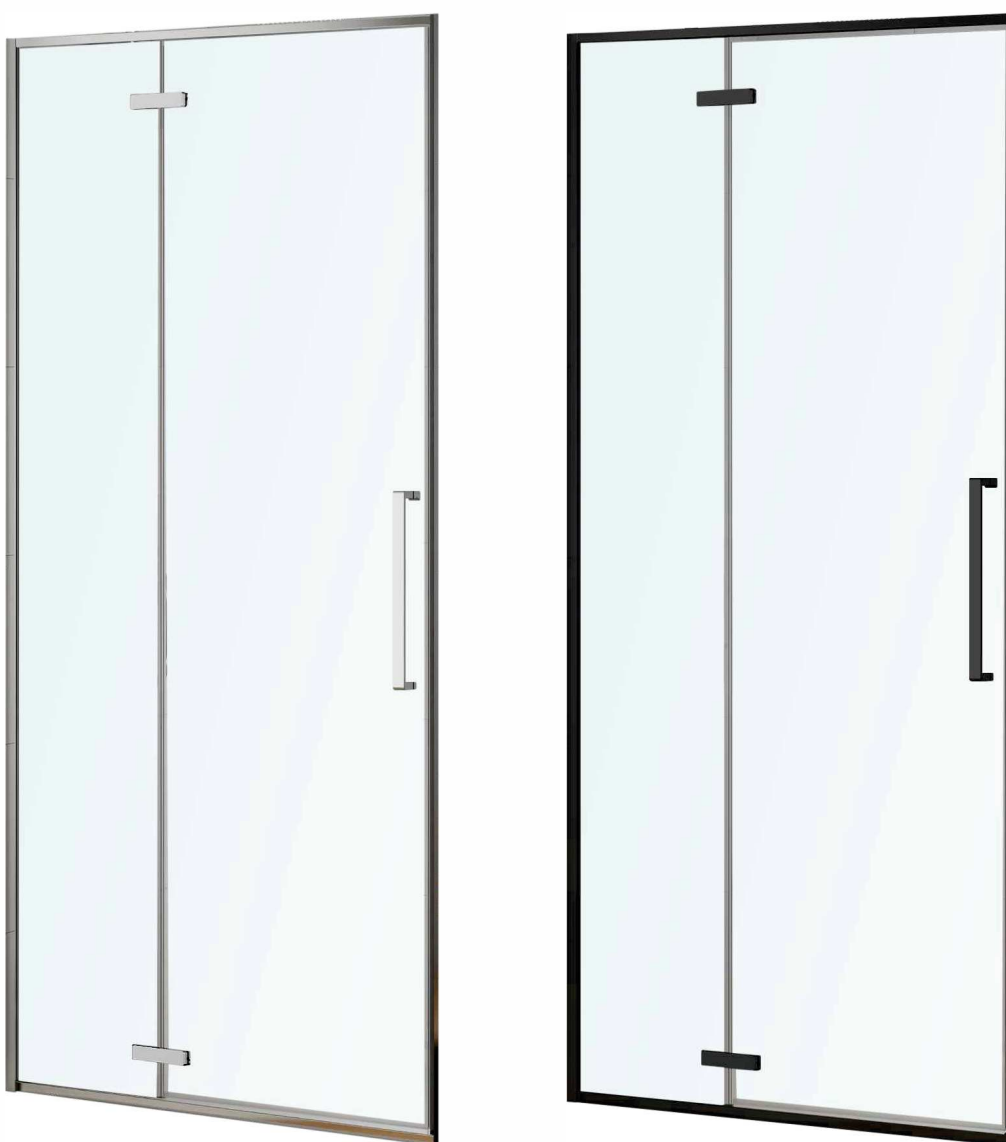

1000 - 1200 x 1950 mm

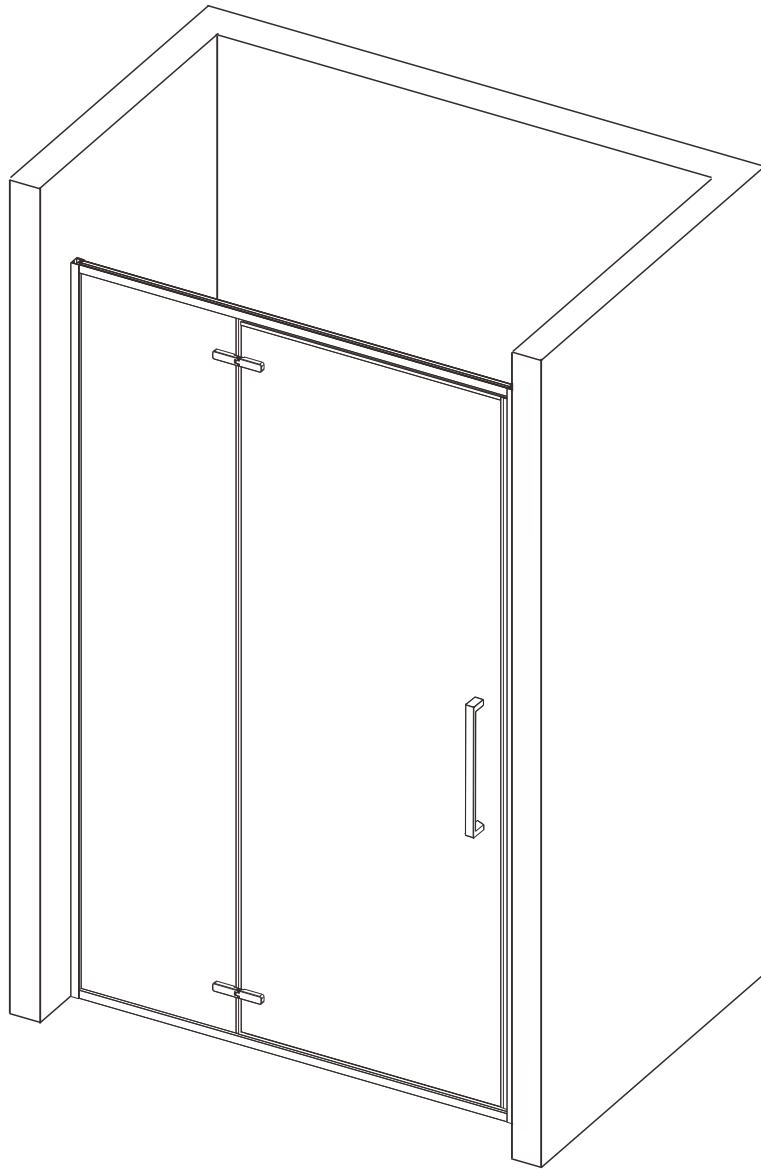

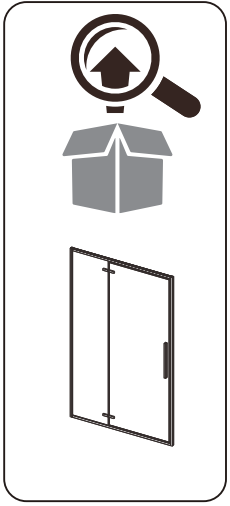
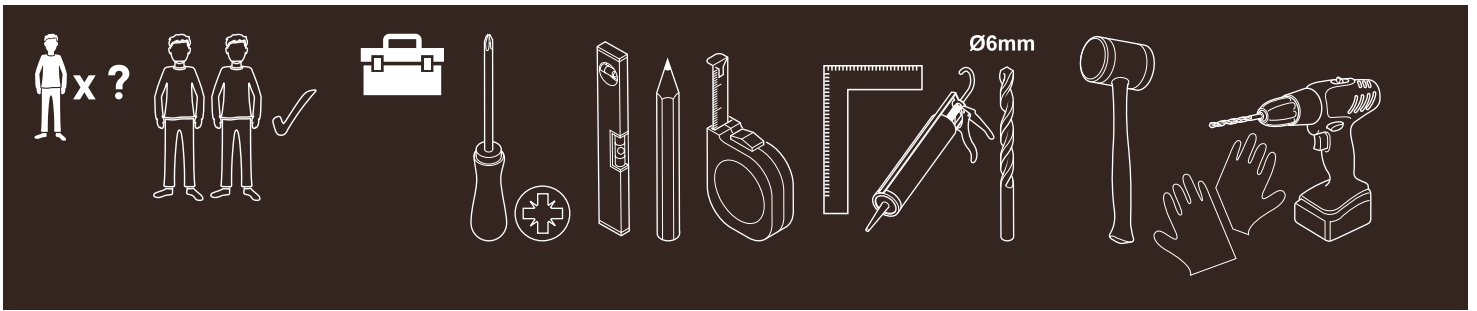

[01] x1



[02] x1



[03] x2



[04] x2

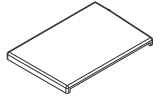

[05]a x1

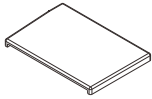

[05]b x1

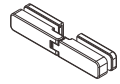

[06] x2

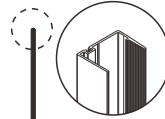

[07] x2

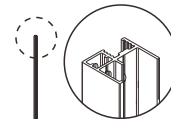

[08] x1



[09] x2

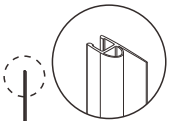

[10] x1



[11] x1



[12] x1

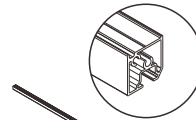

[13] x2

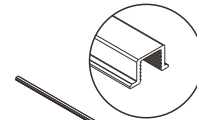

[14] x2

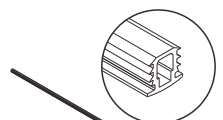

[15] x2

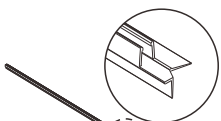

[16]a x1

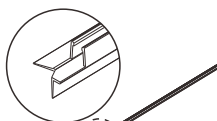

[16]b x1



[17] x1



[18] x6

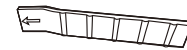

[19] x1



[20] x8

St4x25mm

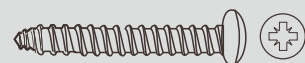

[21] x6

St4x30mm

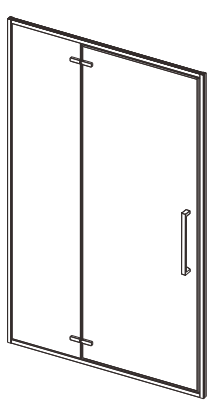
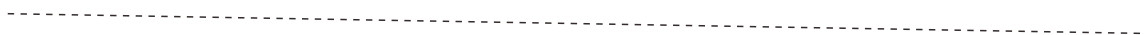
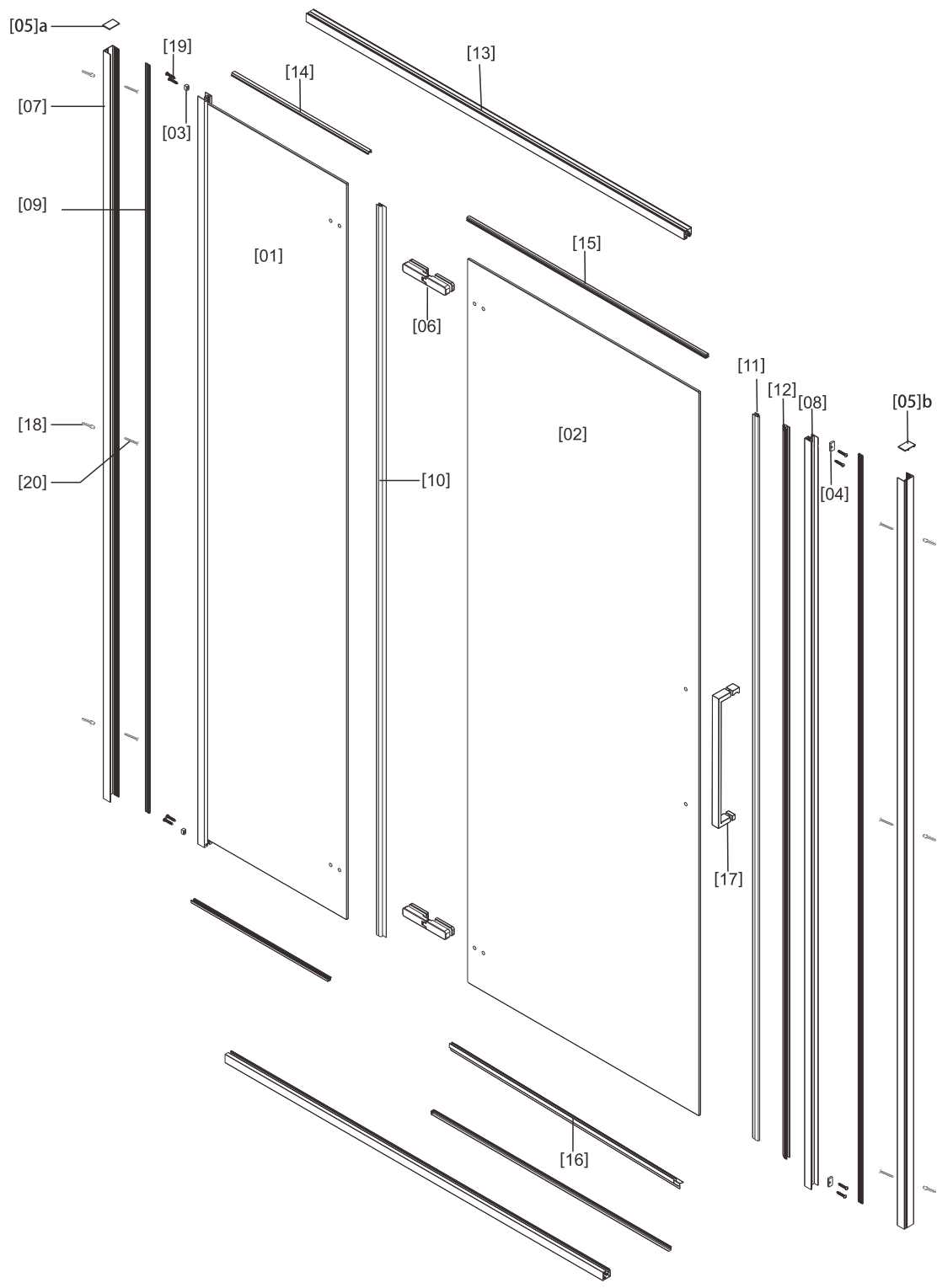

01 - 08

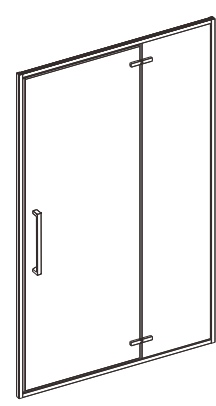

09 - 16

01

A (mm)
980 - 1000
1180 - 1200

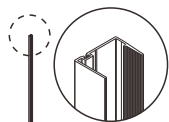

[07] x1



[18] x6

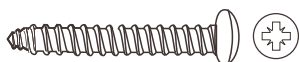

St4x30mm

[21] x3

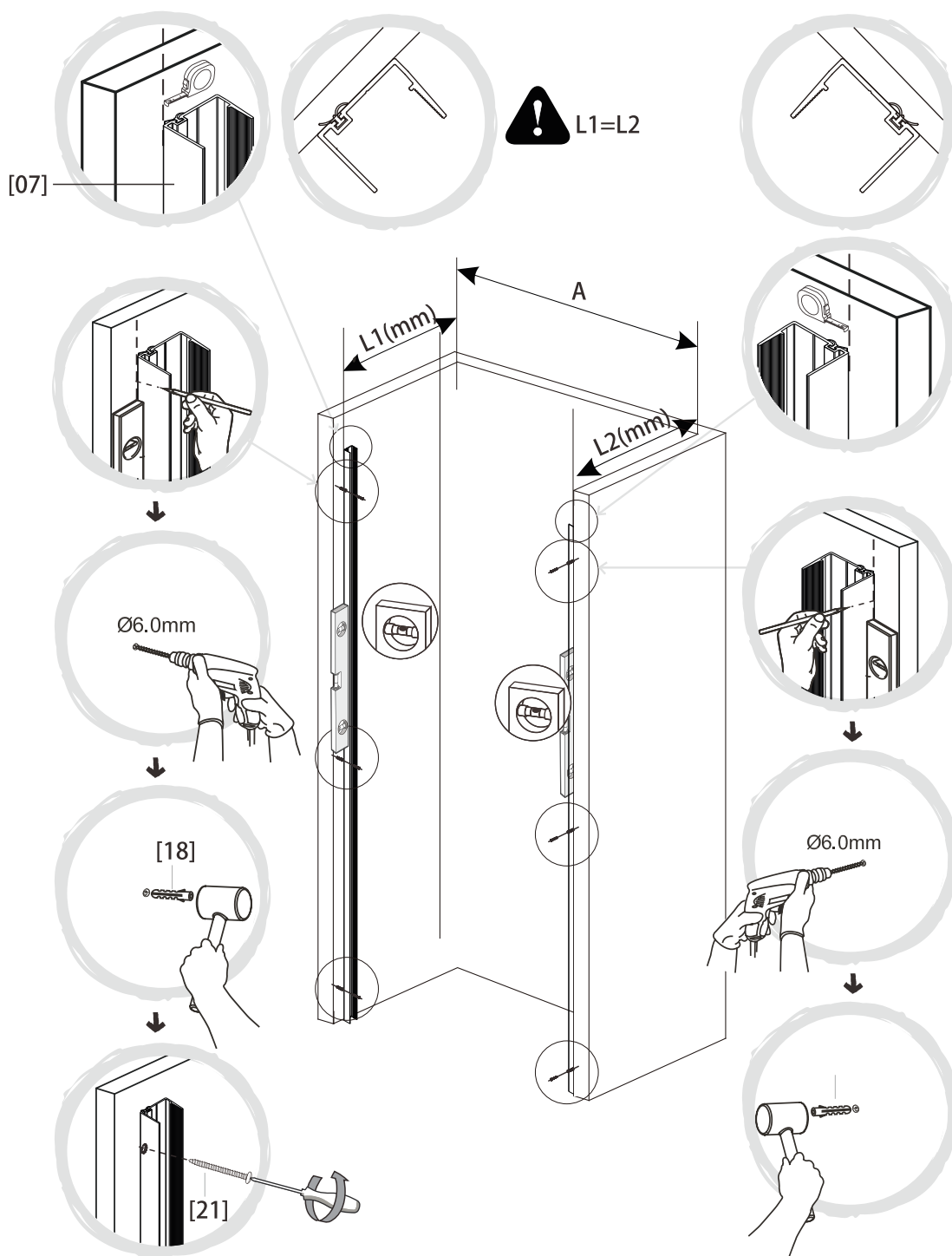

02



[01] x1

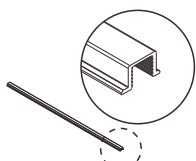

[14] x2

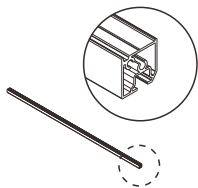

[13] x2



[03] x2



[04] x2

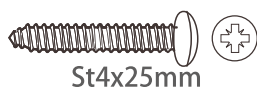

St4x25mm

[19] x8

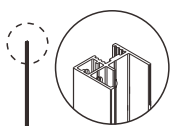

[08] x1

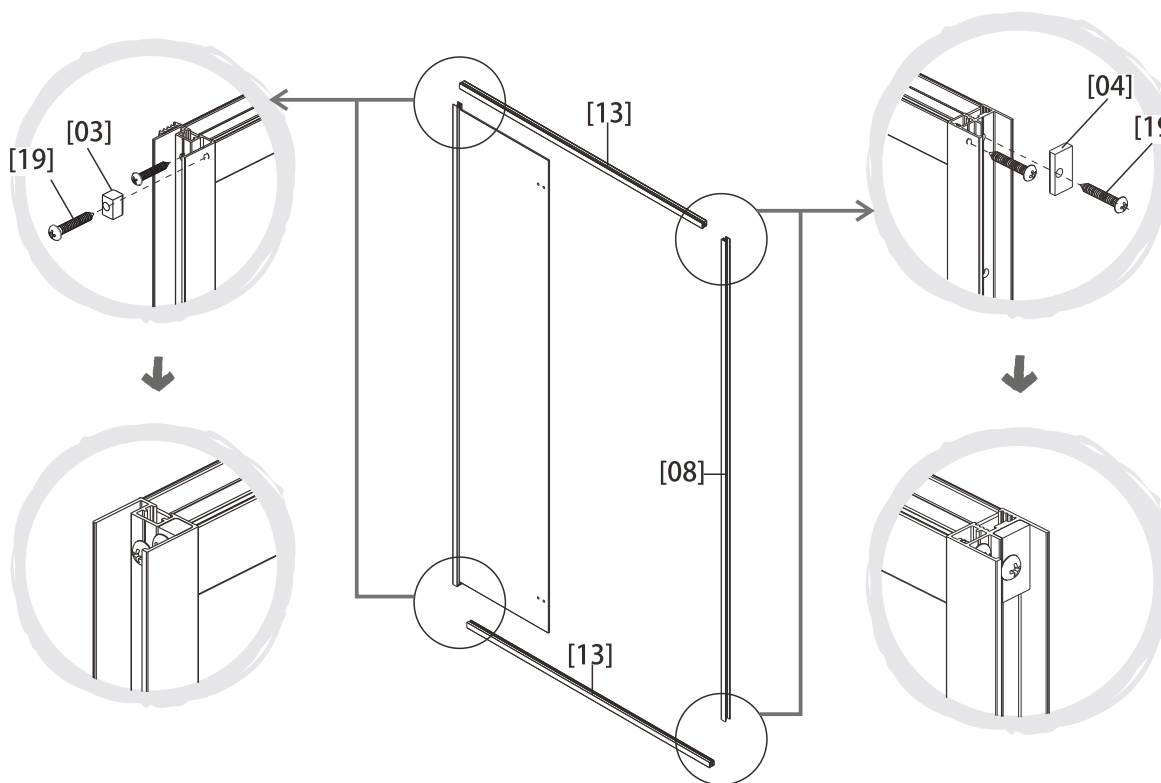
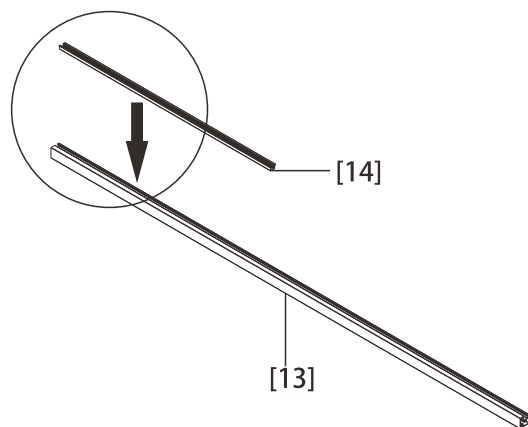
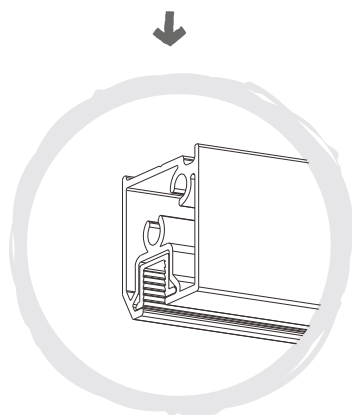
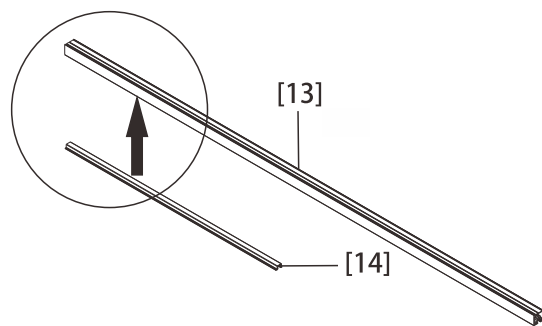
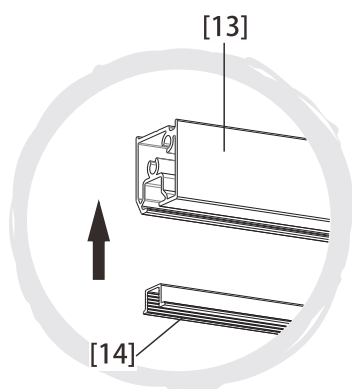

03

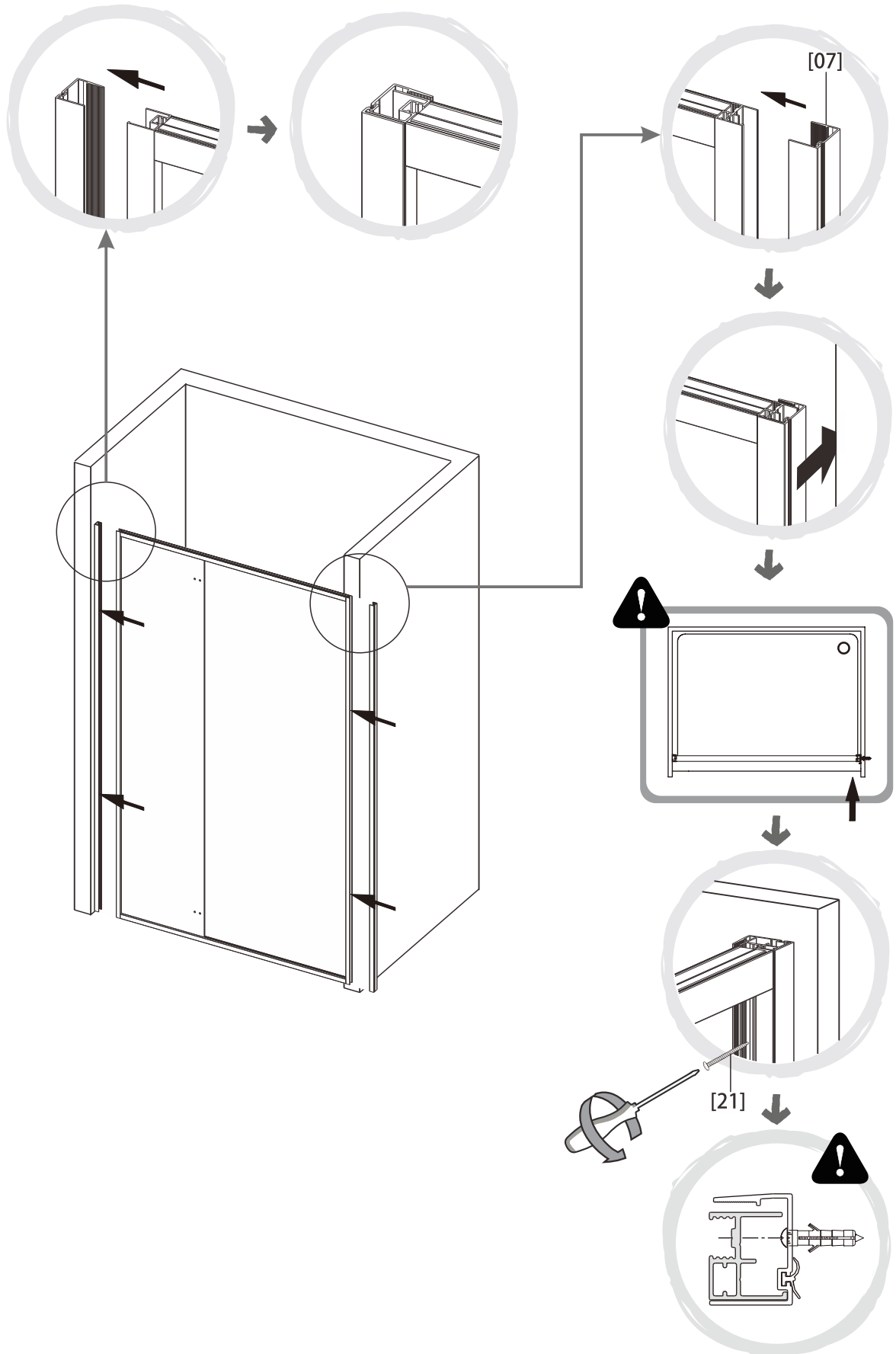
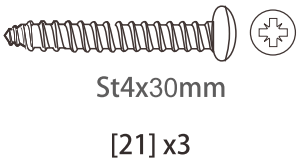
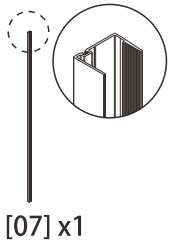

04

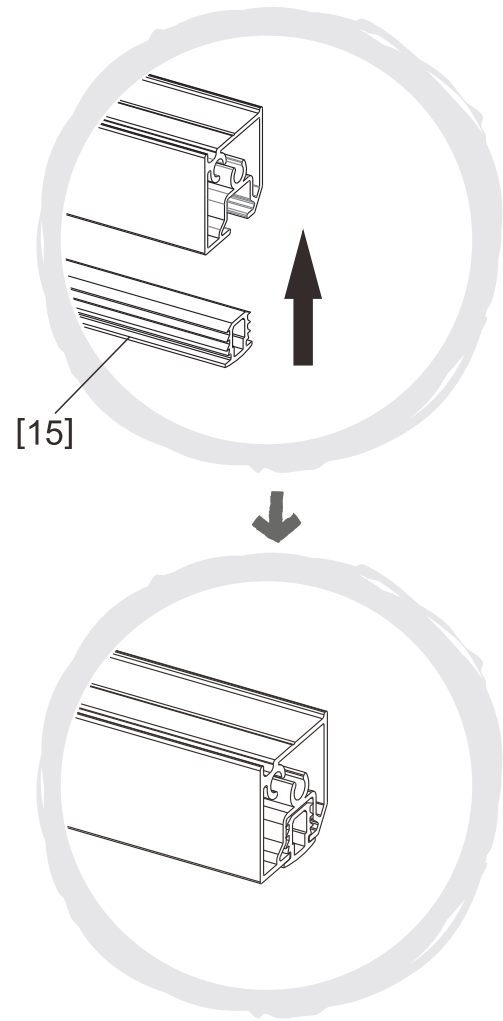
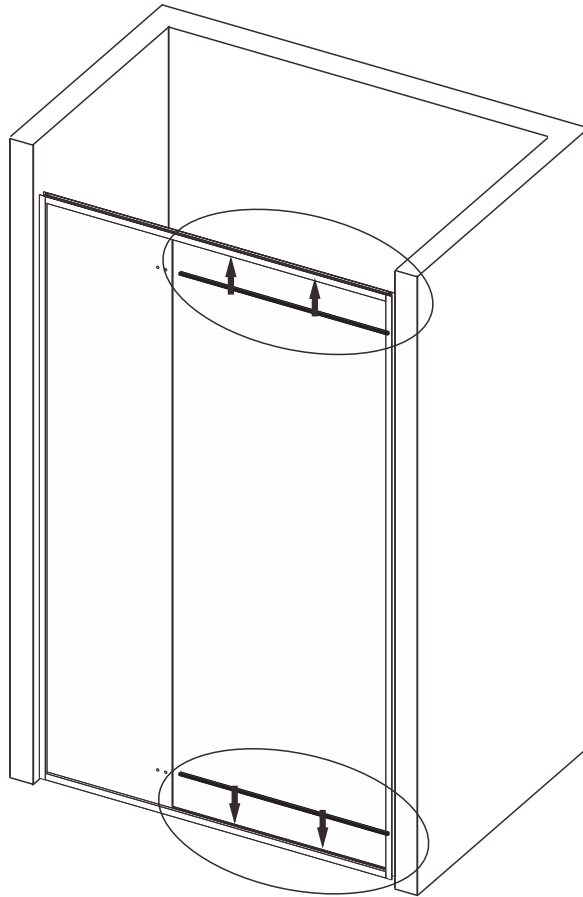
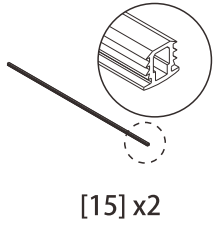

05



[02] x1

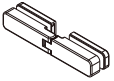

[06] x2



[17] x1

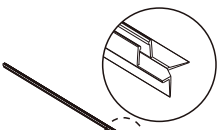

[16]a x1

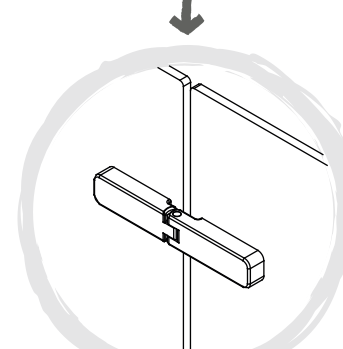
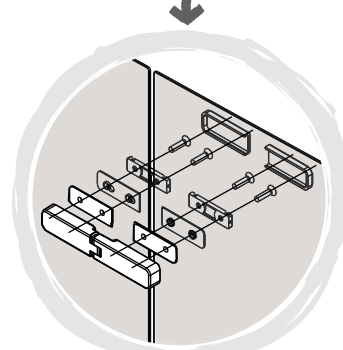
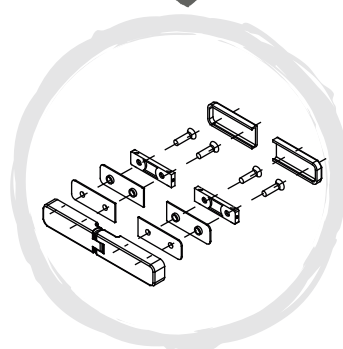
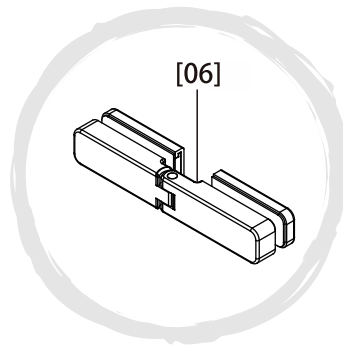

X1 < X2

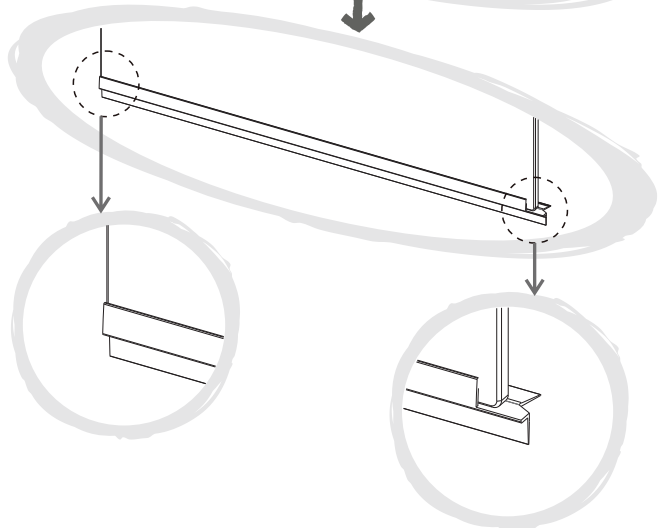
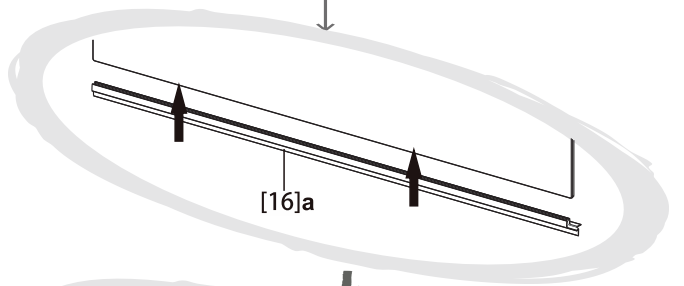
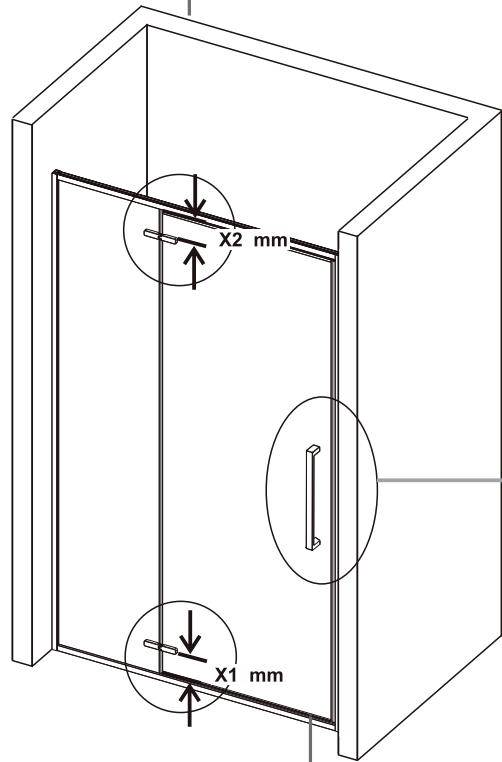
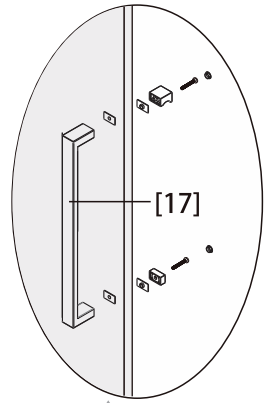

06



[09] x2

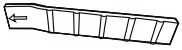

[19] x1

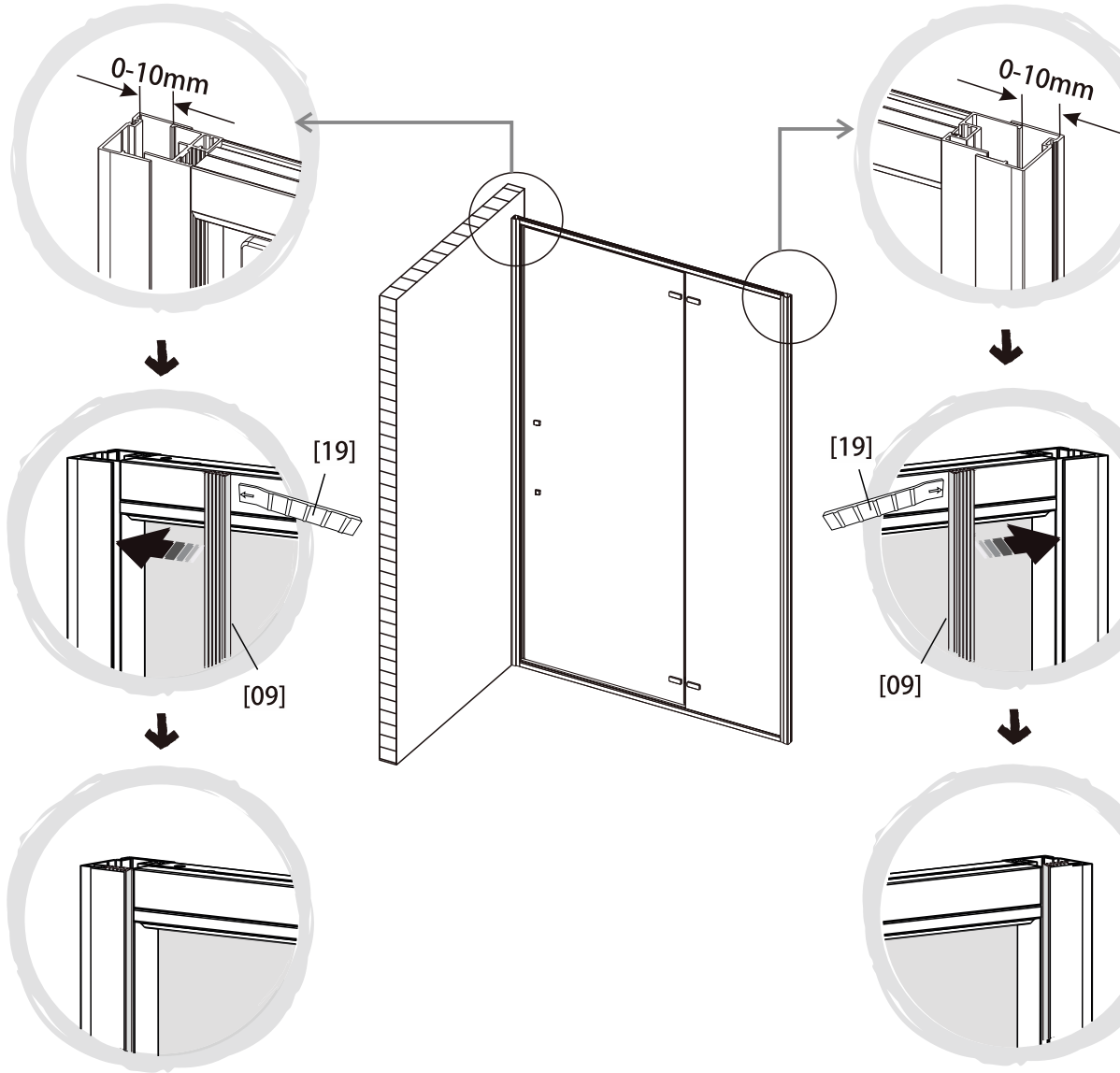

07

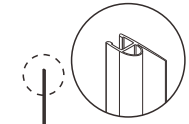

[10] x1

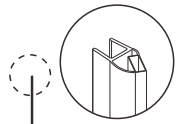

[11] x1

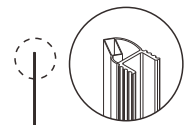

[12] x1

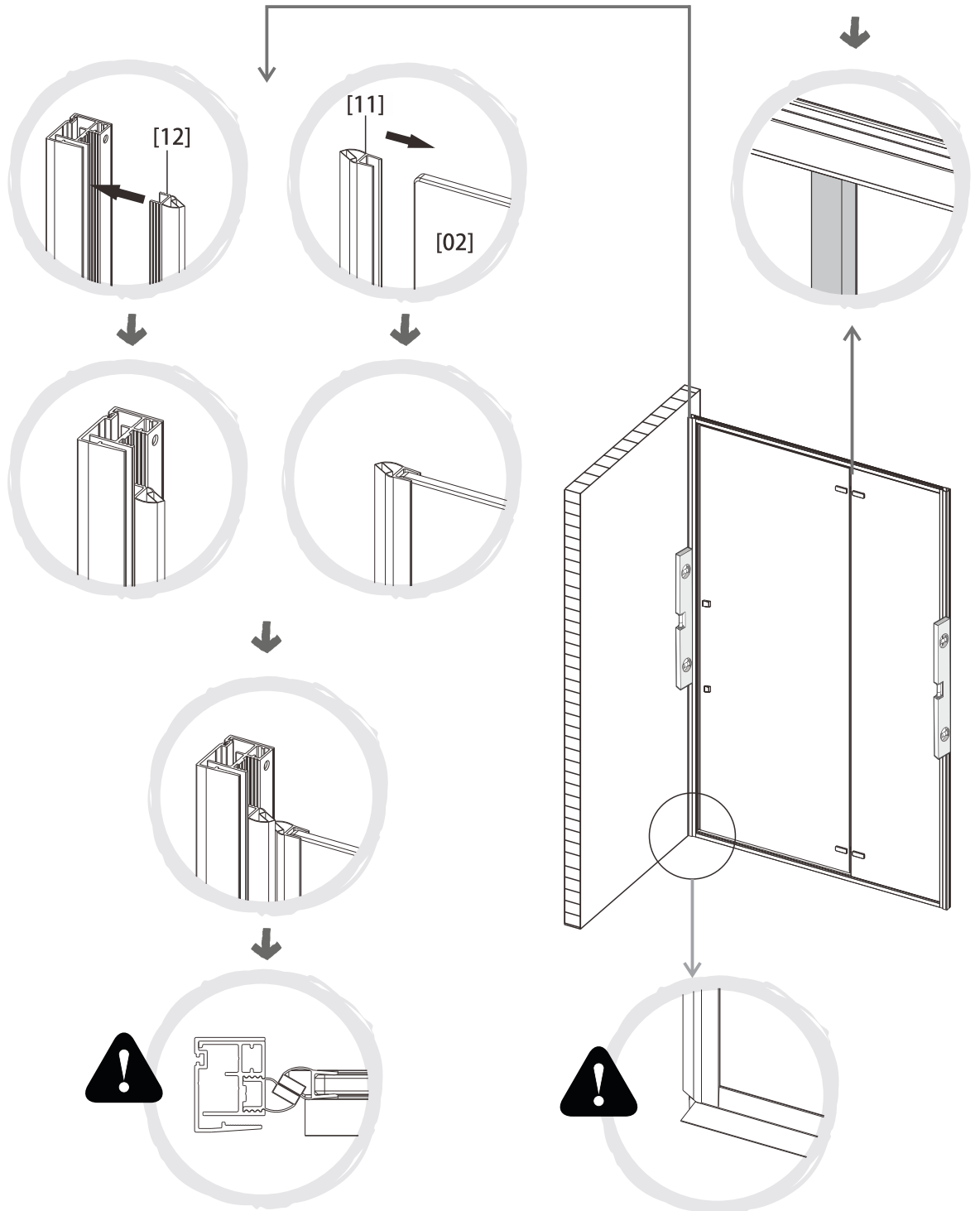

08

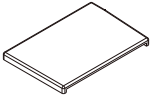

[05]a x1

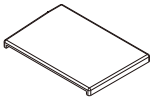

[05]b x1

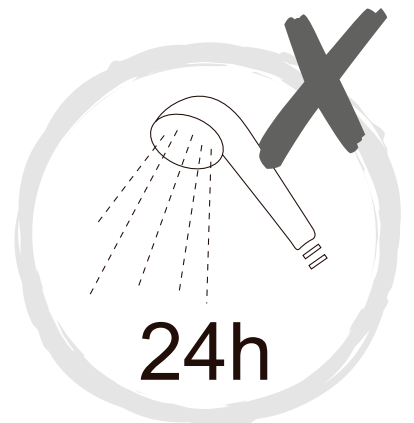
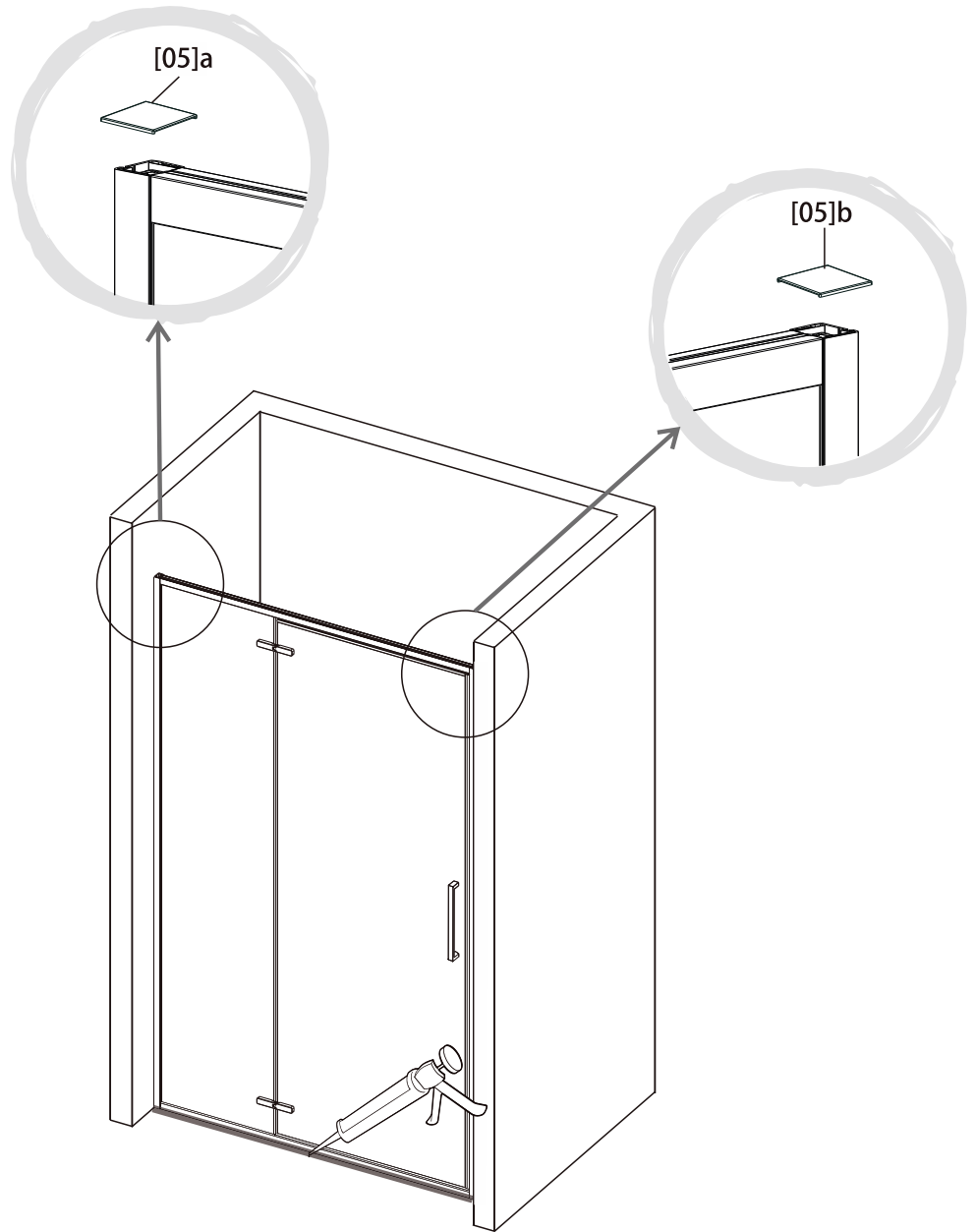

09

A (mm)
980 - 1000
1180 - 1200

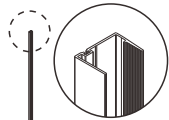

[07] x1



[18] x6

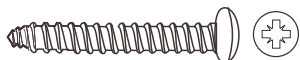

St4x30mm

[21] x3

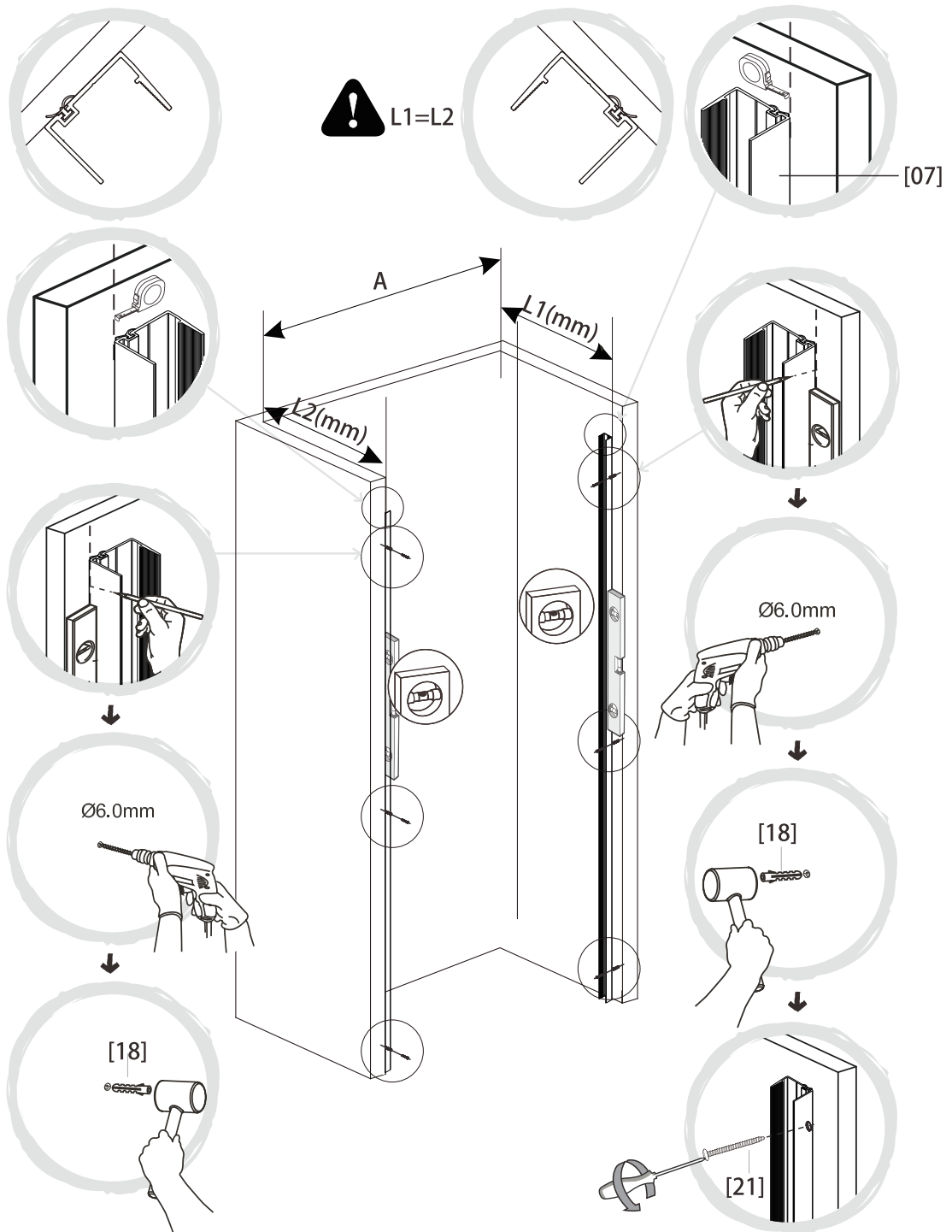

10



[01] x1

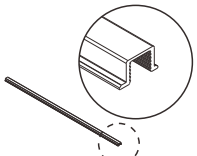

[14] x2

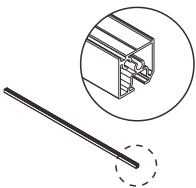

[13] x2



[03] x2



[04] x2



St4x25mm

[19] x8



[08] x1

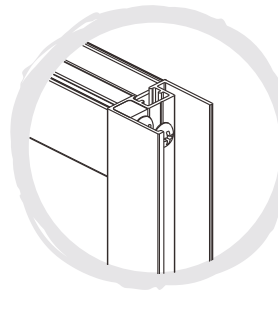
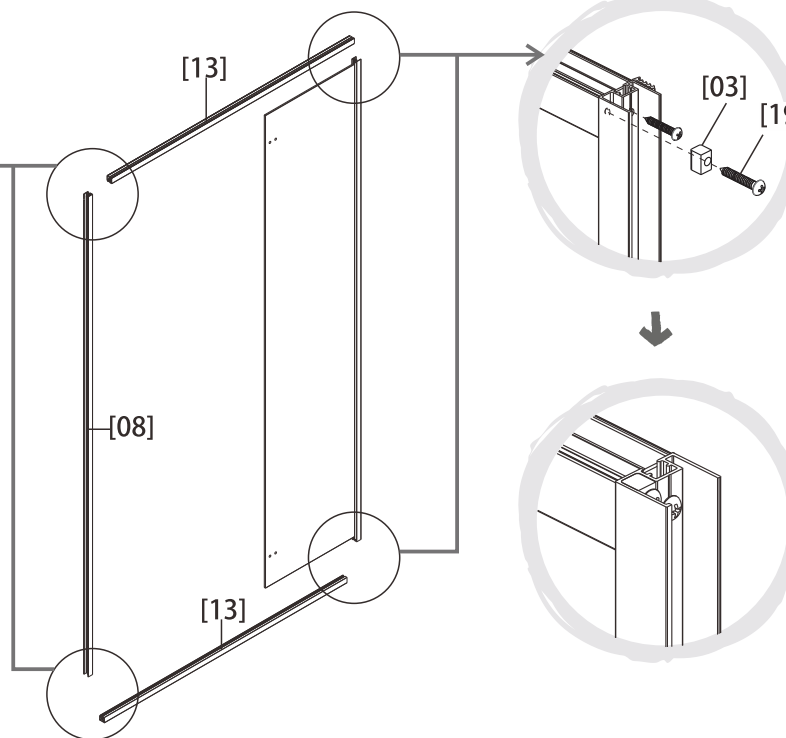
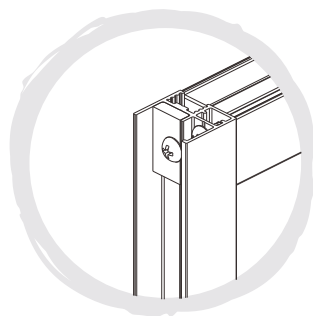
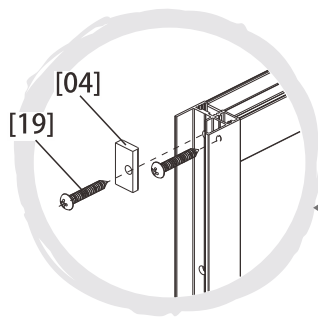
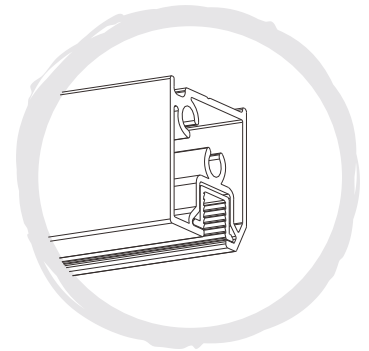
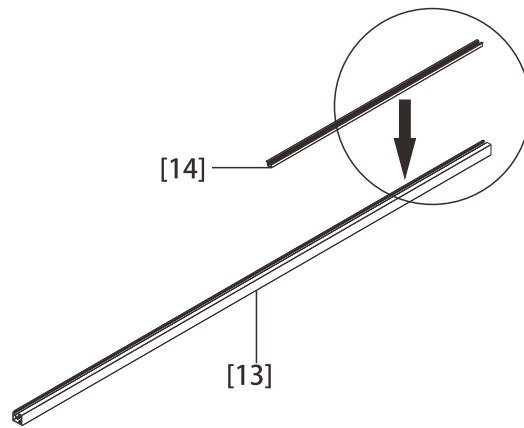
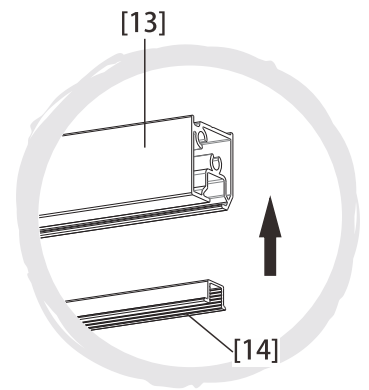
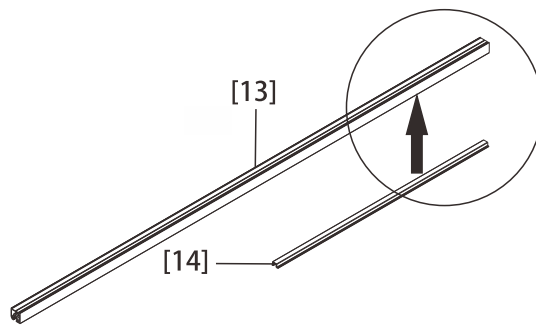

11

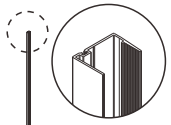

[07] x1



St4x30mm

[21] x3

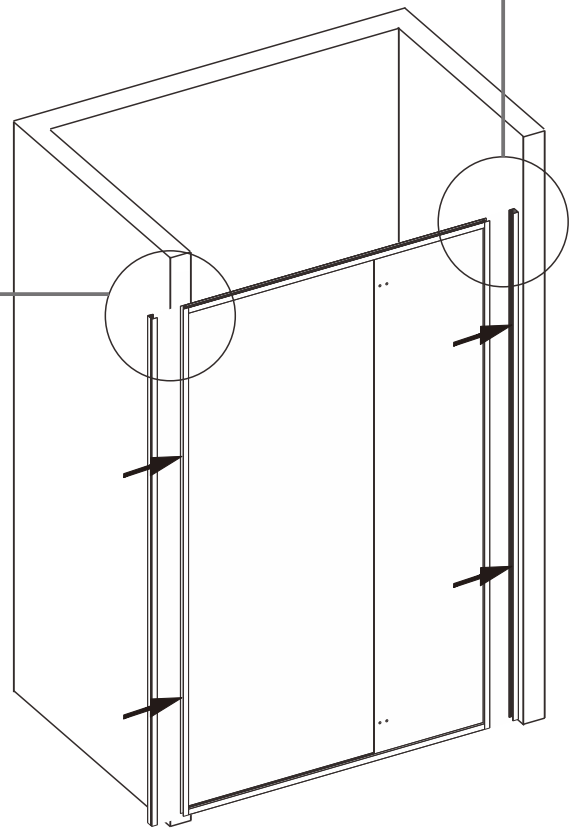
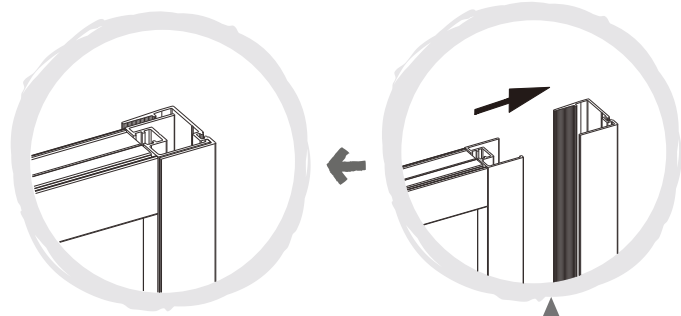
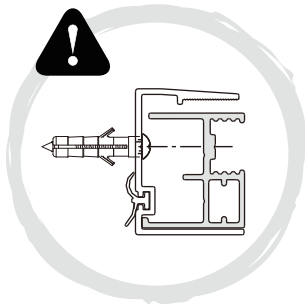
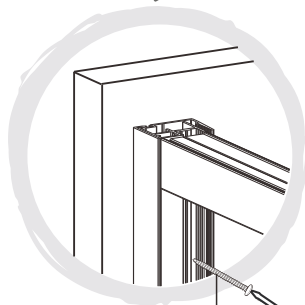
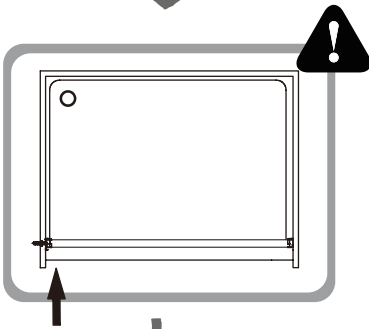
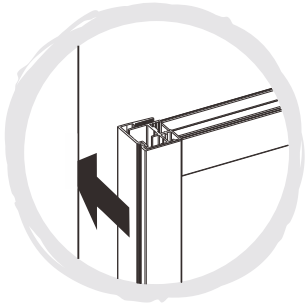
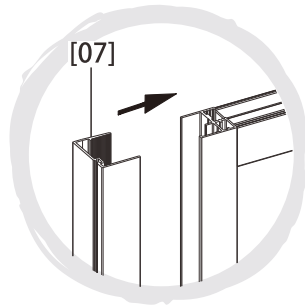

12

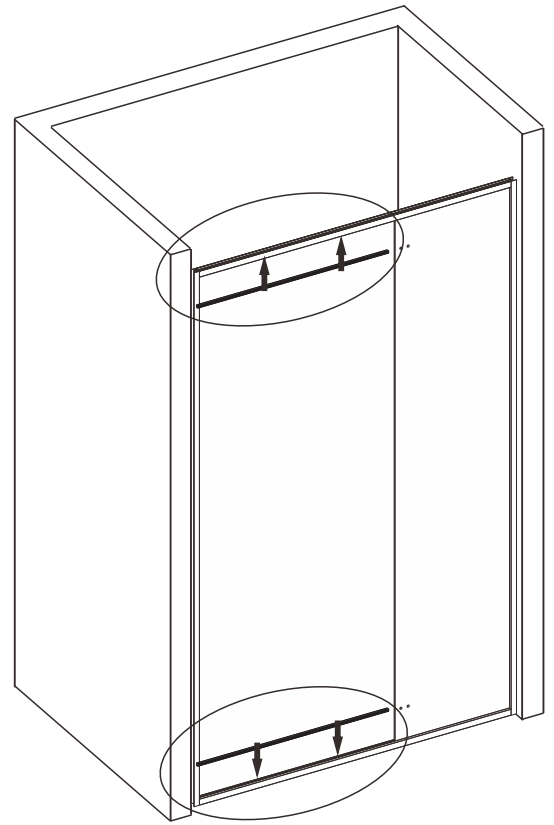
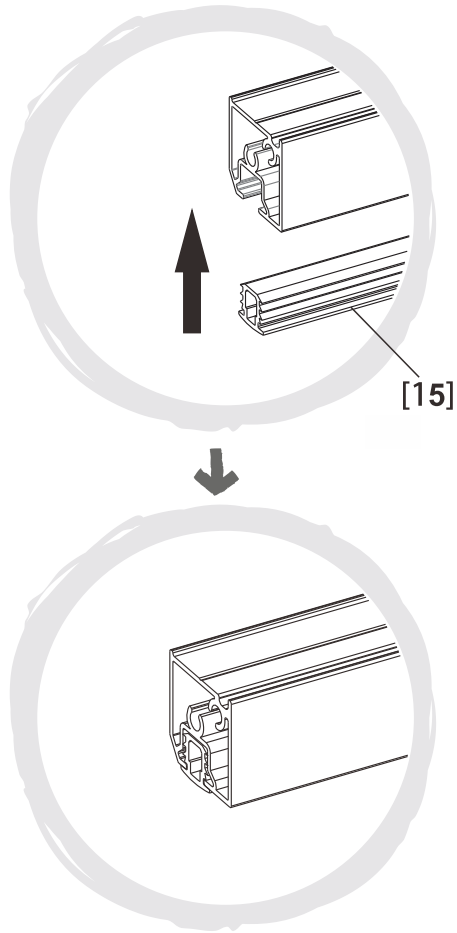
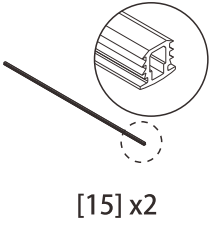

13

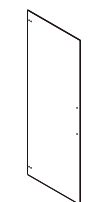

[02] x1

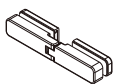

[06] x2



[17] x1

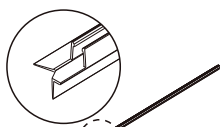

[16]b x1



X1 < X2

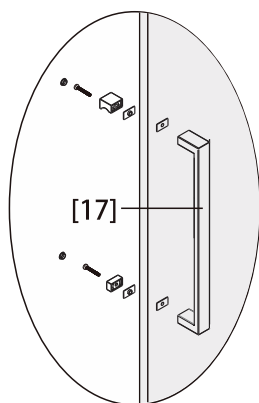

[17]

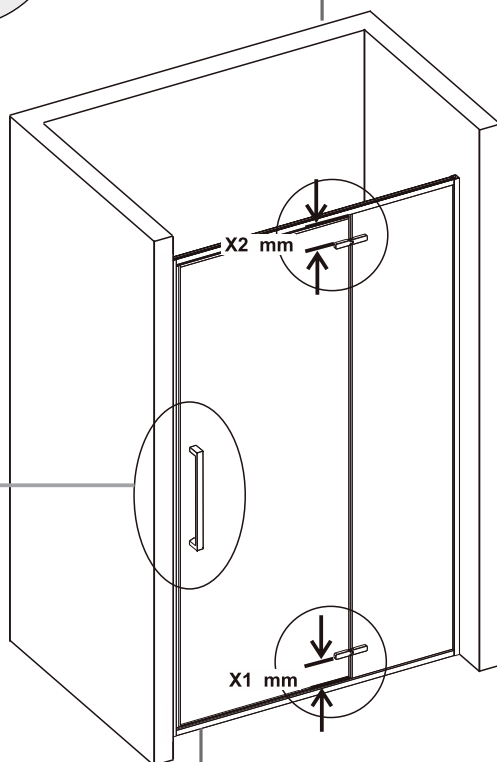

X2 mm

X1 mm

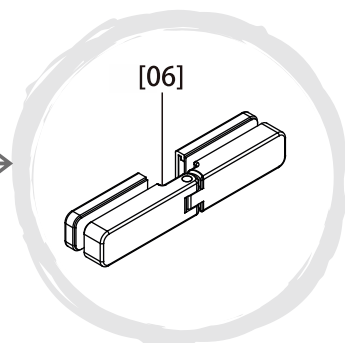

[06]

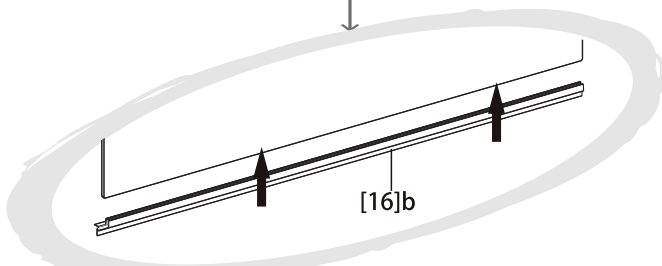
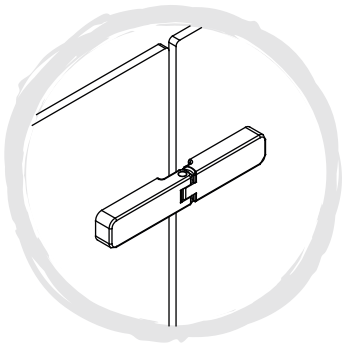
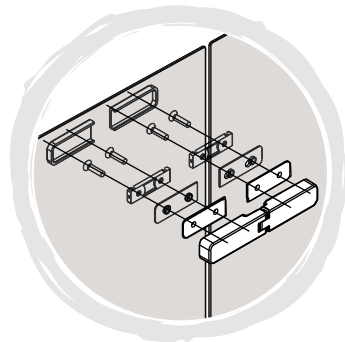
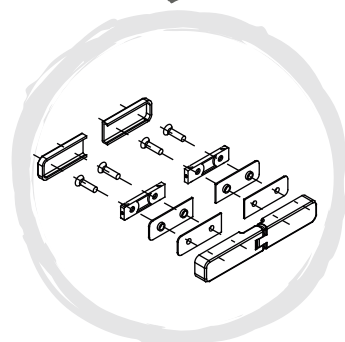

[16]b

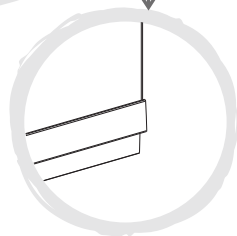
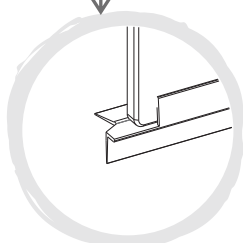
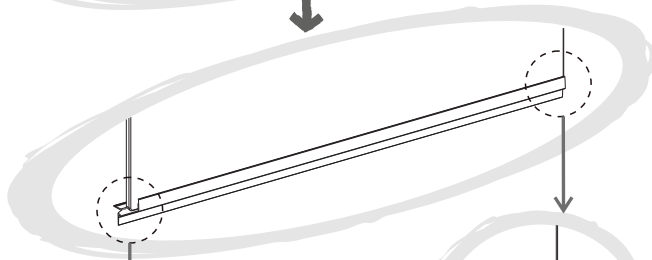

14



[09] x2

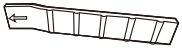

[19] x1

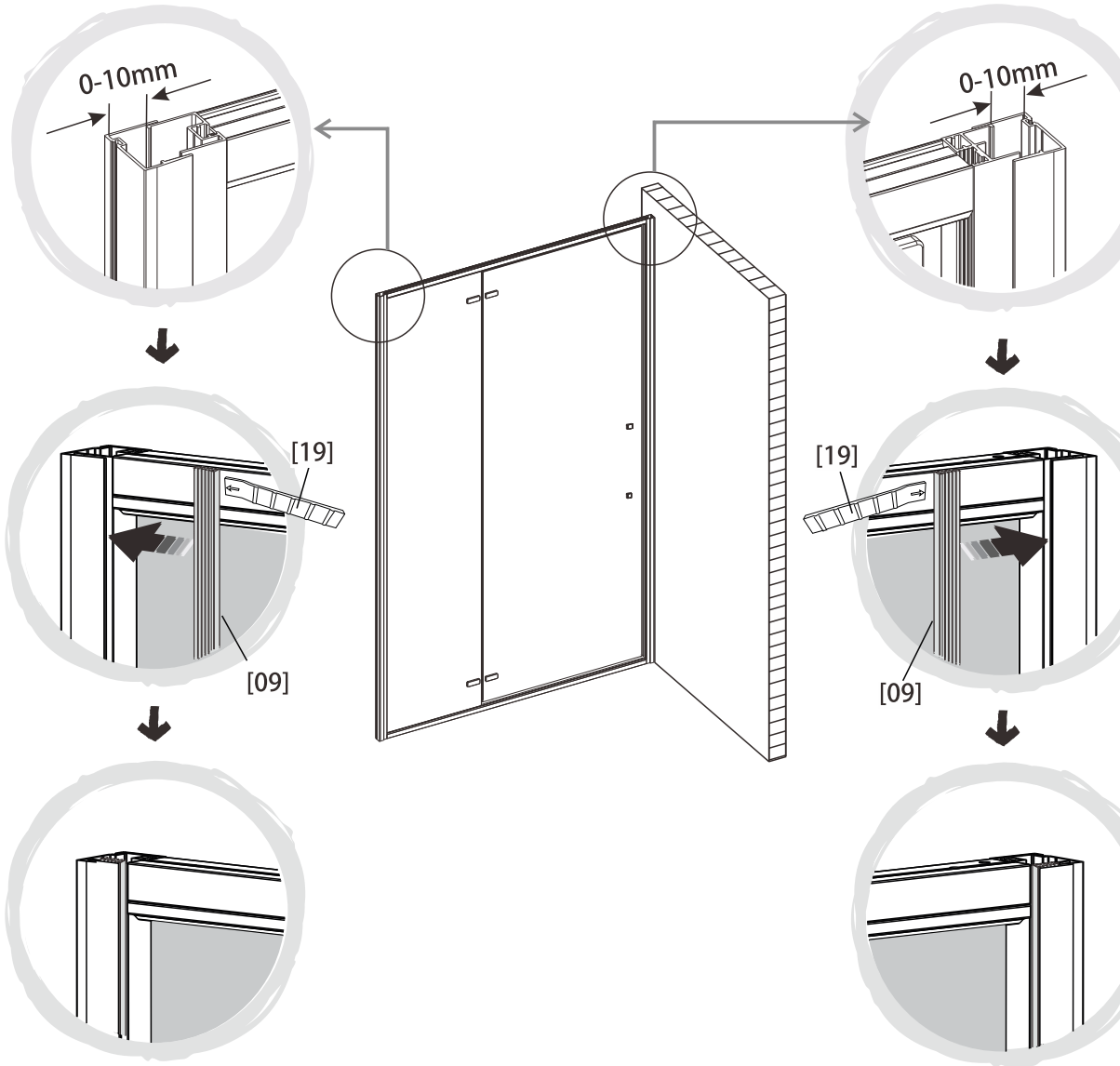

15

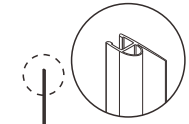

[10] x1

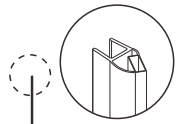

[11] x1

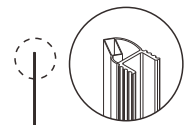

[12] x1

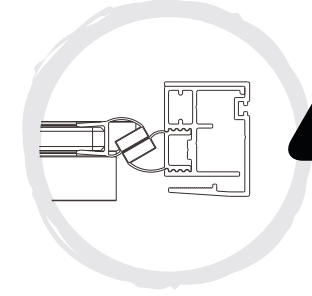
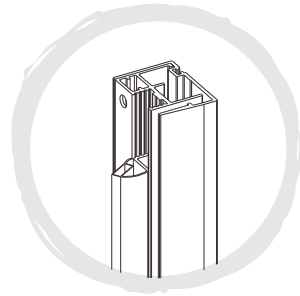
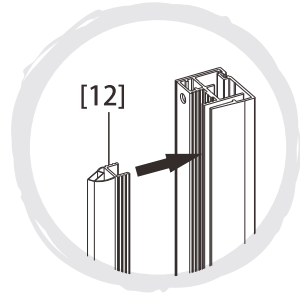
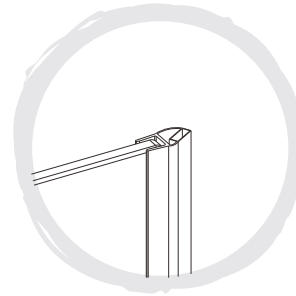
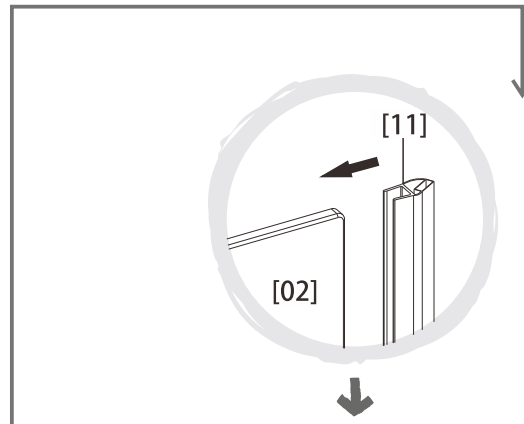
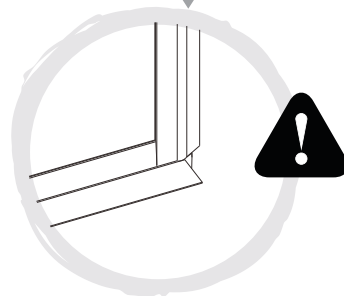
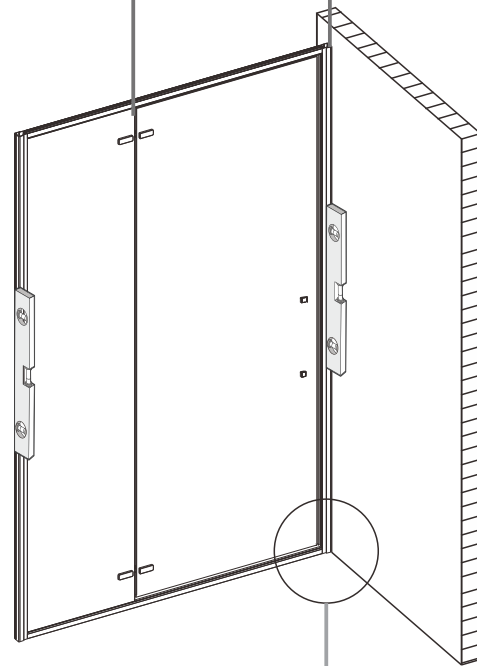
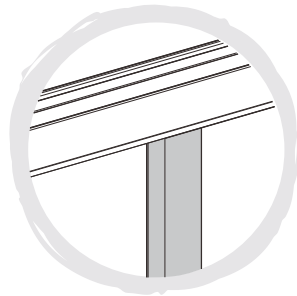
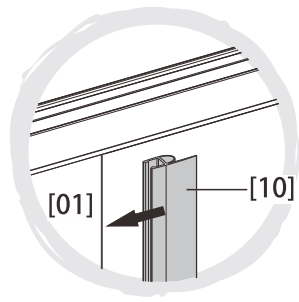

16

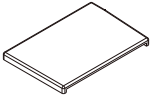

[05]a x1

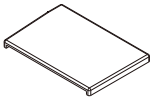

[05]b x1

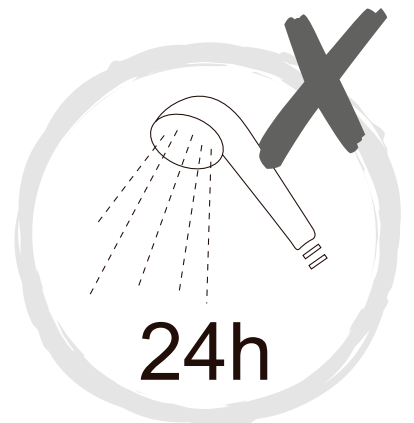
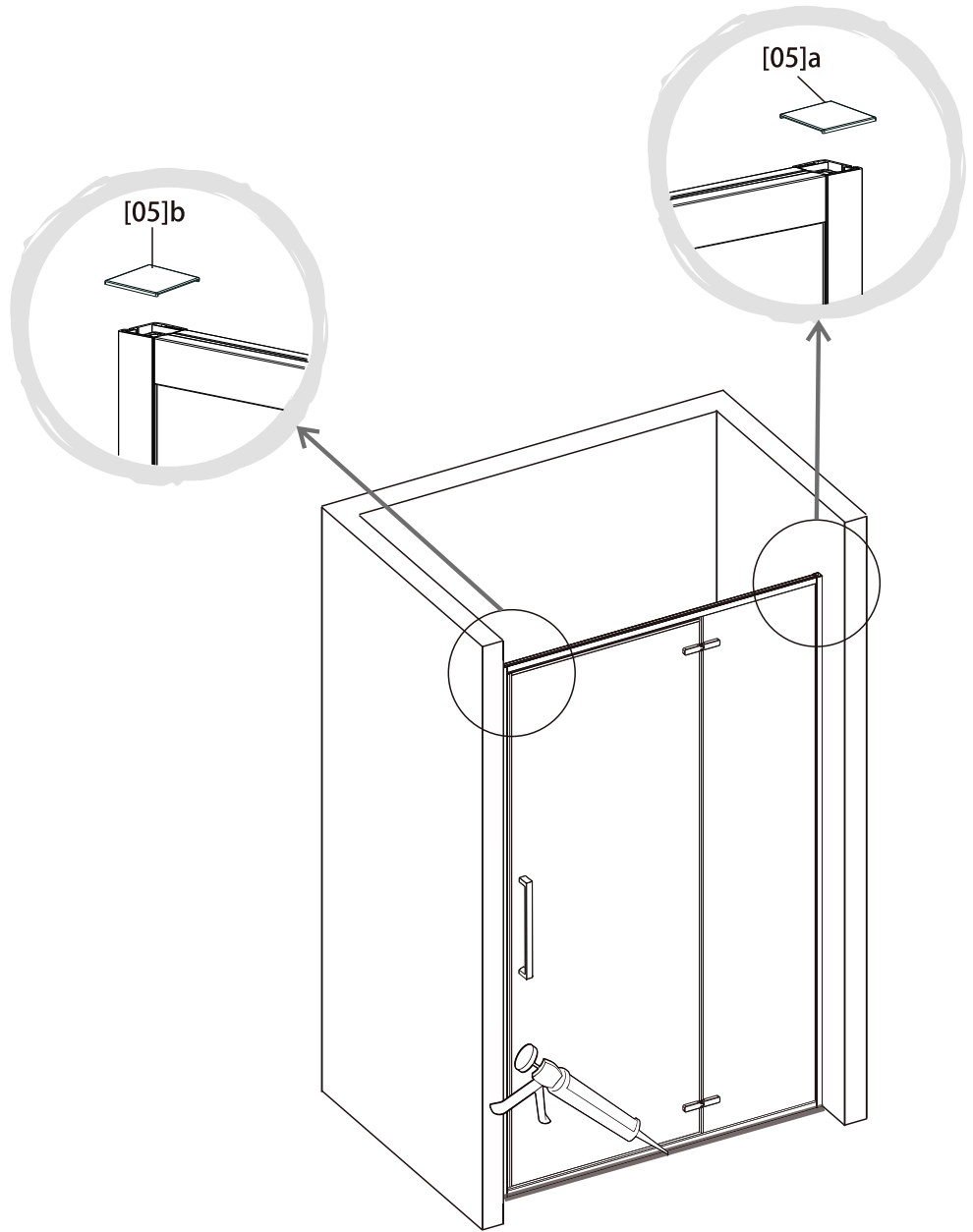

KONSERWACJA

Zabrudzenia na stopie aluminium, elementach plastikowych i szybach należy czyścić przy pomocy miękkiej szmatki zwilżonej łagodnym środkiem czyszczącym. Nie należy używać mocnych środków czyszczących ani wybielaczy, alkoholu, acetonu ani innych rozpuszczalników. Jeśli zabrudzenia są trudne do usunięcia, można je czyścić przy pomocy słabego roztworu octu.

ÚDRŽBA

Zašpinenia na zliatine hliníka, plastových dieloch a sklách treba čistiť pomocou mäkkej handry navlhčenej ľahkým čistiacim prostriedkom. Netreba používať silné čistiace prostriedky, bielidlá, alkohol, aceton ani iné rozpúšťadlá. Keď sú zašpinenia ťažké na odstránenie, je ich možné čistiť pomocou slabého octového roztoku.

ÚDRŽBA

Nečistoty na hliníkové slitině, plastových dílech a sklech čistěte pomocí měkkého hadříku zvlhčeného jemným čisticím prostředkem. Nepoužívejte silné čisticí prostředky ani bělidla, alkohol, aceton a jiná rozpouštědla. Pokud se skvrny odstraňují obtížně, lze je čistit slabým roztokem octa.

KARBANTARTÁS

Az alumínium ötvözetén, műanyag elemeken és üvegezésen jelenő szennyeződéseket egy nedves ruhával, adott esetben tisztítószerral távolítsa el. A tisztításhoz soha ne használjon acetont, alkoholt vagy más típusú oldószert; fehérítőt, vagy erős tisztítószereket. Ha nagyon makacs a szennyeződés, az érintett felületet ecetes vízzel törölhesse át.

ODRŽAVANJE

Priljavštinu na aluminijским i plastičnim elementima te staklima treba čistiti mekom krpom i blagim sredstvom za čišćenje. Ne preporučuje se korištenje jakih sredstava za čišćenje, izbjeljivača, alkohola, acetona ni drugih otapala. Ukoliko je priljavštinu teško odstraniti može se koristiti blaga otopina octa.

ODRŽAVANJE

Nečistoće na aluminijumskoj stopi, plastičnim elementima i staklu treba čistiti pomoću mekane krpice natopljene u blago sredstvo za čišćenje. Ne treba koristiti jaka sredstva za čišćenje kao ni izbeljivače, alkohol kao ni druge razređivače. Ako je nečistoća teška za uklanjanje, može se uklanjati pomoću blagog rastvora sirćeta.